

**UNIVERSITY COLLEGE TATI (UC TATI)****FINAL EXAMINATION QUESTION BOOKLET**

COURSE CODE : DNT 1043

COURSE : COMPUTER ORGANIZATION AND  
ARCHITECTURE

SEMESTER/SESSION : 2 – 2021/2022 &amp; 2022/2023

DURATION : 3 HOURS

**Instructions:**

1. This booklet contains 5 questions. Answer **ALL** questions.
2. All answers should be written in answer booklet.
3. Write legibly and draw sketches wherever required.
4. If in doubt, raise your hands and ask the invigilator.

**DO NOT OPEN THIS BOOKLET UNTIL YOU ARE TOLD TO DO SO****THIS BOOKLET CONTAINS 4 PRINTED PAGES INCLUDING COVER PAGE**

COMPUTER ORGANIZATION & ARCHITECTURE (DCT 1043)

---

## QUESTION 1

- a) State **FOUR (4)** basic functions of computer. (4 marks)
- b) Explain **THREE (3)** main structure components to process the instruction in the computer system. (6 marks)

## QUESTION 2

- a) Show the calculation of those numbers into the binary numbering system.
- i.  $99_{16}$  (2 marks)
  - ii.  $212_{10}$  (2 marks)
  - iii.  $1025_8$  (2 marks)
- b) Show the calculation of those numbers into the hexadecimal numbering system.
- i.  $3456_8$  (2 marks)
  - ii.  $970_{10}$  (2 marks)
- c) Calculate  $-3 -4$  using 6 bit and find the 1st and 2nd complement of it using 8 bits. (6 marks)
- d) List the numbering system that used in computer system. (4 marks)

## QUESTION 3

- a) Illustrate **THREE (3)** types of basic logic gate. (6 marks)
- b) Based on the statement below, sketch an appropriate circuit.
- i.  $Q = (A'BC + BC'D' + DE)'$  (4 marks)
  - ii.  $P = ABC + D'. (E' + F) + C. (D + F')$  (4 marks)

## COMPUTER ORGANIZATION &amp; ARCHITECTURE (DCT 1043)

- c) According to the figure 1 below, list out an appropriate Boolean Expression. (4 marks)

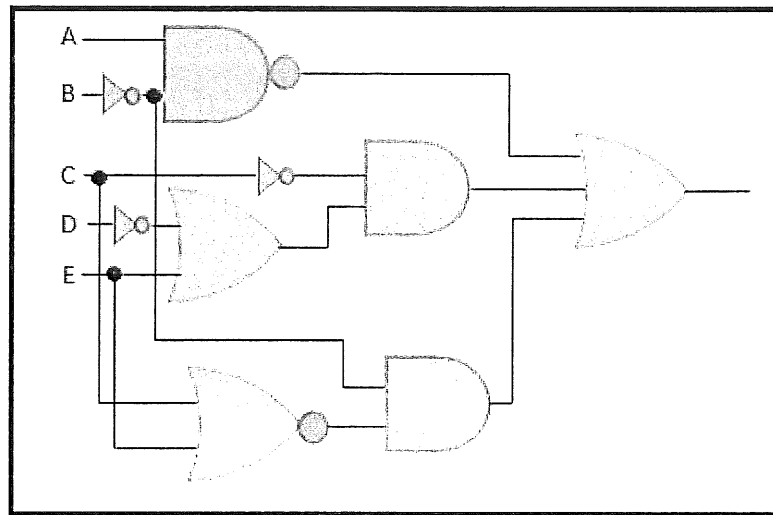

Figure 1: Logic Circuit

## QUESTION 4

- a) Construct truth table that  $P = (ABC' + BCD + CD)'$  for each A, B, C and D in (0, 1) (8 marks)
- b) List **FOUR (4)** basic laws of Boolean algebra. (4 marks)
- c) State **FOUR (4)** major functions or requirements for an I/O module. (4 marks)
- d) Draw the connection between I/O module with CPU and Main Memory. (6 marks)

COMPUTER ORGANIZATION & ARCHITECTURE (DCT 1043)

---

## QUESTION 5

- a) List types of primary memory and secondary memory. (4 marks)
- b) Compare between Internal Hard Disk and External Hard Disk. (6 marks)
- c) Assume MM size is 8K and cache size is 4K. Cache is divided into 2 slots. From this information, find out how much size of each SLOT and the total NUMBER of BLOCKS reside in MM? (6 marks)
- d) List **FOUR (4)** types of secondary memory. (4 marks)
- e) State **THREE (3)** types of input and **THREE (3)** types of output device. (6 marks)
- f) List **FOUR (4)** comparison between hard disk and solid-state disk. (4 marks)

-----END OF QUESTIONS-----